

SURFACE ADJUSTABLE DOWNLIGHT

NICOLE

Surface mounted small and large luminaires with tilt and rotational adjustments. Perfect for concrete ceiling applications for illumination of works of art, over benches or in corridors. Fixed in the vertical position for a discrete and effective surface downlight. Excellent high quality finish in powder coated white or matt black.



FITTING COLOURS

BLACK  WHITE 

Lumax	NICOLE S	NICOLE L
Input		240V
Body	Die Cast Aluminium	
Lens	Clear	
Driver	Integral	
Connection	Quick Connect	
LED Diodes	Epistar	
Beam Angle	40°	
Wattage	9W	13W
Dimmable	Yes	
Lumen Output	750lm	1000lm
Power Factor (PFC)	0.98	
Colour Rendering Index (CRI)	>85	
Correlated Colour Temp (CCT)	3000K	
IP Rating	IP20	
Electrical Class	Class 1	
Operating Temp. Range	-20 +50deg	
Warranty	3 Years	

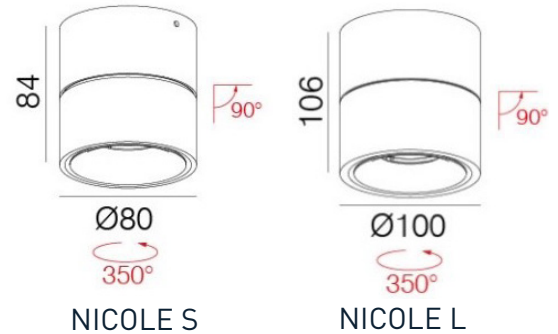

INPUT VOLTAGE
240V



OUTPUT POWER
NICOLE S **9W**
NICOLE L **13W**



LUMENS
NICOLE S **750lm**
NICOLE L **1000lm**



COL TEMP
3,000K



WARRANTY
3 YEARS

